

REVISION RECORD			
REV	DESCRIPTION	DATE	APPD

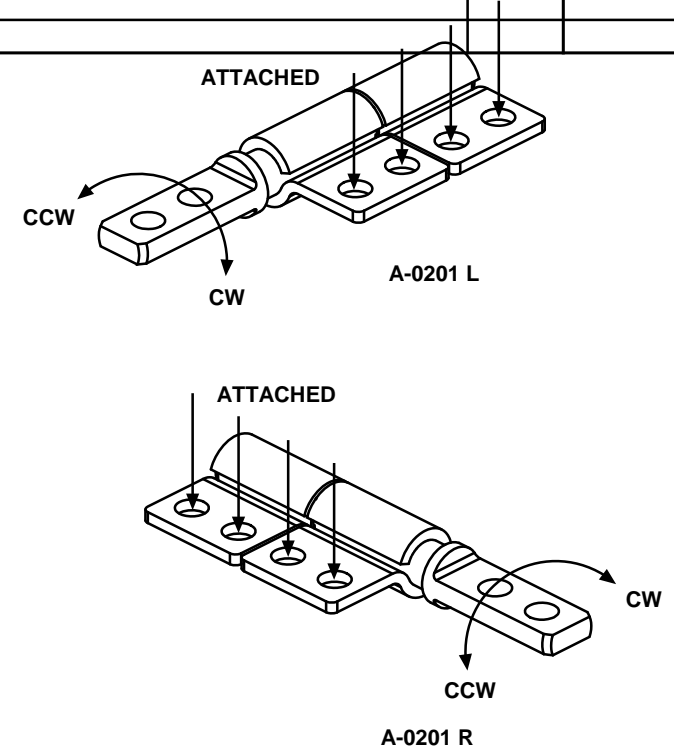
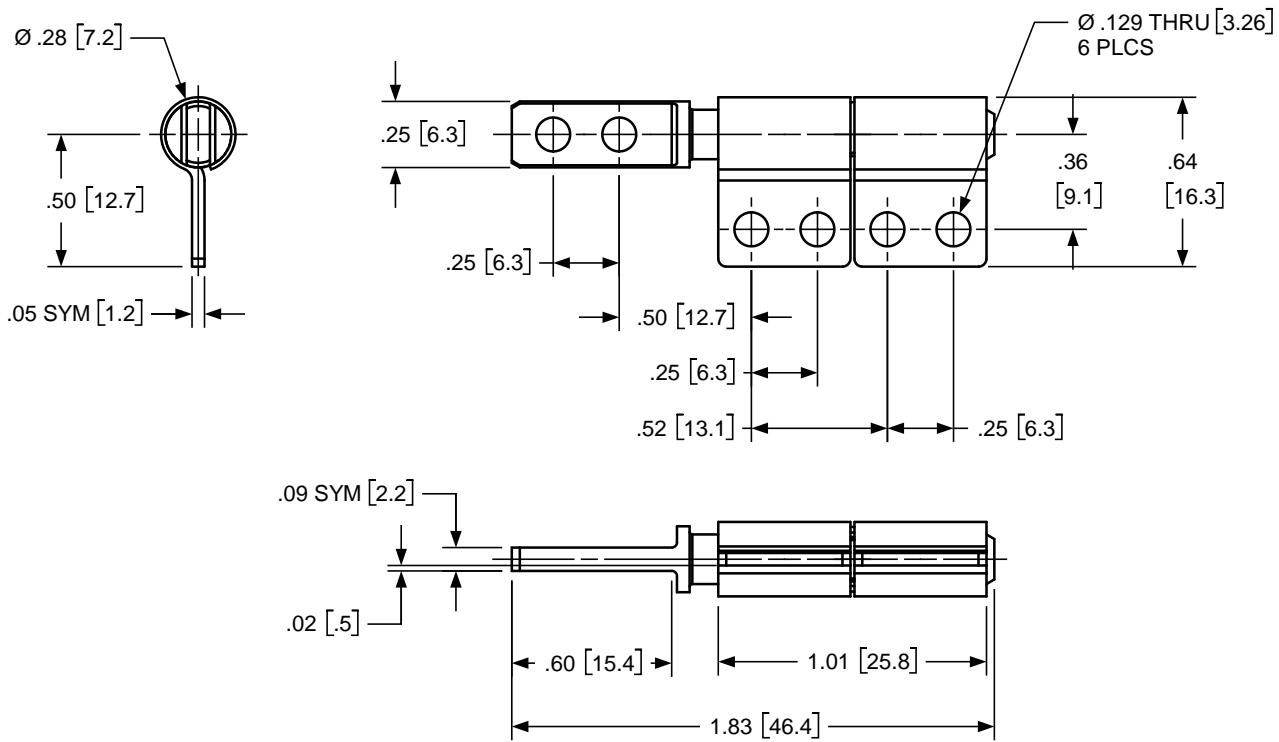

- NOTES:
- HINGE TORQUE: UNBALANCED.
  - Torque Range  
 Low : 10.0 -16.0 in.lb  
 Med. : 14.0 -20.0 in.lb  
 High : 18.0 -24.0 in.lb

<b>SHINELOT</b>		TITLE <b>INTERFACE DRAWING</b>			
ALL INFORMATION ON THIS PRINT ARE PROPRIETARY TO SHINELOT, AND SHALL NOT BE USED IN WHOLE OR IN PART WITHOUT SHINELOT'S CONSENT.		ENGLISH / METRIC		MATERIAL	
		TOLERANCES		<b>STEEL BAND &amp; SHAFT</b>	
		METRIC .X ±.3 MM .XX ±.13 MM .XXX ±.005 MM	ENGLISH .XX ±015 IN .XXX ±005 IN .XXXX ±0002 IN	SIZE <b>B</b>	DWG NO <b>A-0201</b>
		DRAWN BY			REV <b>A</b>
USED ON	REV	ANGLE ±1°		SCALE <b>2:1</b>	DATE
				SHEET	<b>1 OF 1</b>